

Model NX-PR06330 Three-Way In-Wall Speaker System

Congratulations on choosing NXG In-Wall Loudspeakers. Like all NXG products, great care has been taken in their design. Their combination of advanced engineering and state-of-the-art materials will provide you with years of listening pleasure, while blending smoothly into your home's decor. Before you get started, it is a good idea to identify all the parts and hardware (See Fig. 1).

Where To Place Your In-Wall Speakers

Placement can make all the difference in how your speakers sound, and how easy they will be to install. Carefully consider where your speakers should be positioned. For optimum performance, speakers should be mounted to the left and right of the main listening position and a minimum of 8 to 10 feet apart (See Fig. 2). Avoid mounting speakers in stud cavities containing electrical wiring, heating ducts, water pipes, etc. Make sure the wall or ceiling materials are sturdy enough to support the weight of the speakers.

In-Wall Placement: Optimum performance will be achieved when your speakers are mounted at ear level or slightly higher. If you desire to mount them higher in the wall, turn the speaker over so the tweeter is closer to the listening area.

In-Ceiling Placement: Optimum performance will be achieved when your speakers are mounted to the left and right of the main listening area.

Adjustable Tweeters (Fig. 3)

The tweeters in all NXG Pro Series speakers may be adjusted, allowing you to tailor the speaker to better fit the listening area. The overall smoothest response is achieved with the tweeter facing straight out; however, you may find the sound more pleasing by aiming tweeters toward a particular listening area. To adjust the tweeter, apply pressure on the ring surrounding the tweeter with your thumb or finger.

Tweeter/Midrange Level Adjustments (Fig. 3)

The level switches allow you to tailor the speakers' frequency response to better match the room's acoustics. As an example, if a room has a hardwood floor, which makes it acoustically brighter sounding, you may want to adjust the tweeter and midrange levels to compensate. You can experiment with both levels to find the sound that's most pleasing to you in your particular listening environment.

Mirror Image (Fig. 4)

It is recommended that your speakers be mounted with the tweeters facing the inside as shown.

Speaker Installation In Existing Construction (See Fig. 5 on reverse)

Once you have selected the location for your speakers, you are ready to install them.

You will need the following:

- Stud Finder
- Drill & Drill Bits
- Wire Cutter/Strippers
- Pencil
- Utility Knife or Drywall Saw
- Small Level
- Masking Tape
- Phillips Screwdriver
- Speaker Wire

NXG recommends the use of 16-gauge wire minimum. For wire options consult your retailer or custom audio contractor.

1. NXG Architectural Speakers are designed to be installed in the wall area between studs. Using a stud finder, make sure you are between two studs. Using the supplied template and a level to ensure your template is straight, trace around the outside with a pencil.

2. Cut the hole using your drywall saw. You may want to start with a small hole in the center of the outline. This will allow you to check for any obstructions that may exist behind the desired location. **CAUTION:** Be certain electrical wiring, water pipes or heating ducts do not interfere in the planned installation areas prior to drilling or cutting the wall.

3. Run speaker wire from your amplifier or speaker switching device to the speaker location.

4. Carefully remove the grille and inner grille backing. (Note: The open cell foam inner grille backing is designed to hide speaker components from view and may be removed if desired.) If you like the standard white finish of your NXG speakers, skip to step 5, but if you want your speakers to blend in with a colored wall or ceiling, now is the time to paint your speaker's outer frame and

(Continued on reverse)

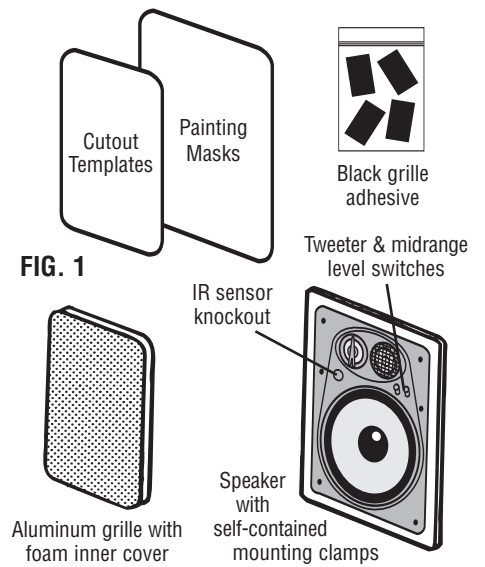

FIG. 1

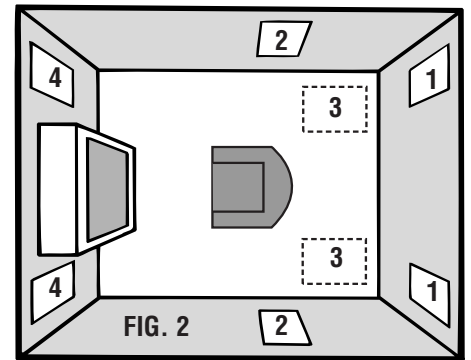

FIG. 2

NXG Pro Series In-Wall Speakers can be used as rear surround sound channels by placing them (1) behind, (2) on each side of viewer, or (3) in the ceiling just behind viewing position. They also make excellent front channel home theater speakers (4).

Press on the edge of the tweeter to rotate

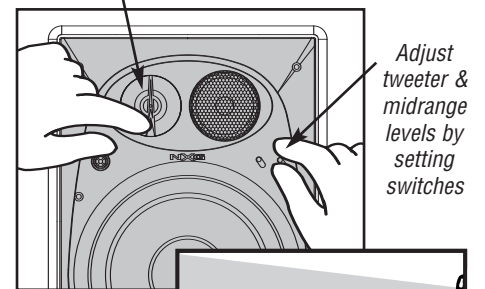
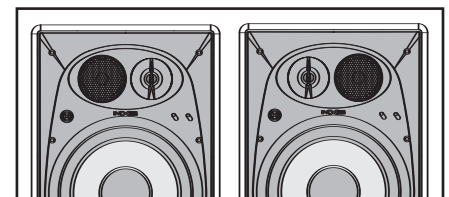

FIG. 3



FIG. 4



Recommended mounting configuration for mirror-image speakers (tweeters facing inside)

(Continued from front)

perforated grille. (Remove the foam inner grille backing and put it aside in a clean and dust free area for later reinstallation if desired.) The speaker's outer surface will accept ordinary latex wall paint or aerosol spray paint. Because the speaker baffle surface behind the grille should remain unpainted, you will need to cover this area with the supplied cardboard paint mask. Cover the speaker's interior black surface, woofer and tweeter. Paint the outer speaker frame and grille separately. (Grille painting hint: Use a paint roller that is nearly out of paint to first paint the inside of the grille, then the outside. This will avoid paint filling the grille perforations.)

5. Attach the wire to the input terminals on the rear of the speaker. Remember to maintain proper polarity with the amplifier by attaching the positive (+) lead to the red terminal and the negative (-) lead to the black terminal.

6. See Fig. 6. With the speaker wire attached to the speaker, slide the speaker up inside the cut-out hole. Center the speaker in the cut-out hole and turn the six locking screws clockwise until the speaker is drawn up snugly to the wall board from behind, clamping the speaker in place. Try to tighten each screw equally. Replace the speaker grill by gently pressing it into place.

New Construction

1. Determine speaker locations and mark them on your plans for future reference.
2. If possible, run speaker wires after HVAC and electrical wiring is in place.
3. Secure speaker wires in place along the run with insulated staples only and be careful not to pierce the wire's insulation. Allow a bit of slack for expansion of building materials.
4. Needless to say, the actual speakers should not be installed until the wall board is in place. In the meantime, leave several feet of wire coiled up and secured at the back side of the mounting hole.
5. To complete the installation follow steps 2 through 5 above.

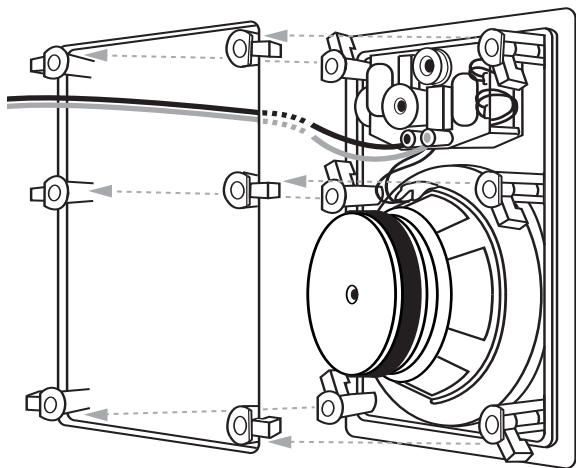

FIG. 6

Operational Check

After making all connections it's a good idea to make sure everything is working properly. Turn on your surround or stereo system making sure the volume control is turned down and that the balance control is in the center position. Activate a musical or movie source such as FM, a CD or DVD player. Gently turn up the volume, you should hear sound coming from your new NXG speakers. If no sound is heard from any or all speakers, switch off the system immediately and check for open or loose connections, wrong polarity or shorts, or proper source selection.

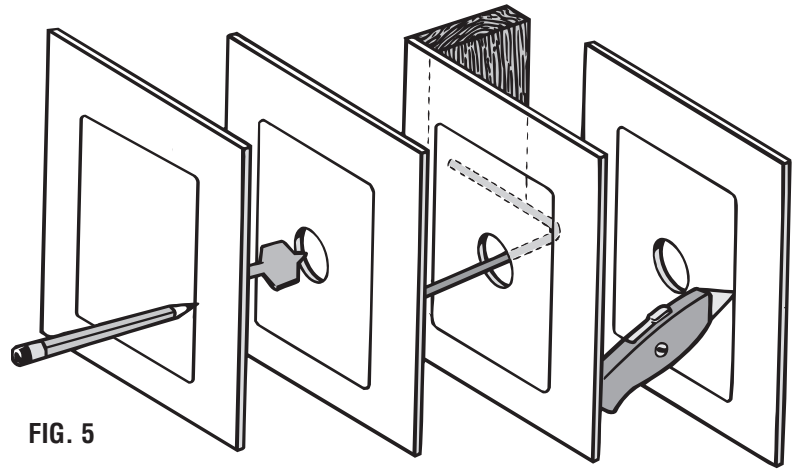

FIG. 5

NX-PR06330 Specifications

Power Handling: 5 - 120 watts

Efficiency: 90dB @ 1 watt/1 meter

Frequency Response: 38 Hz - 22,000 Hz

Driver Complement: 6 1/2" (165 mm) metallic anodized injection molded radiative cone woofer with rubber surround
2" (50 mm) metallic anodized mylar cone midrange
1" (25 mm) pivoting liquid-cooled metallic anodized dome tweeter

Impedance: 8 ohms nominal

Grille: Corrosion-resistant powder coated aluminum

Overall Dimensions: 12" H x 8 5/8" W x 3 1/2" D

Required Wall Cut-out: 10 7/8" H x 7 1/2" W

NXG Speakers Three-Year Limited Warranty

If the NXG speaker system proves to be defective in workmanship or materials within three years from the date of the original customer's purchase, we will, at our option, repair or replace the defective product.

Limitation of Implied Warranties

Any implied warranties, including warranties of merchantability and fitness for a particular purpose, are limited in duration to the length of this warranty.

Exclusion of Certain Damages

NXG's liability for any defective product is limited to repair or replacement of the product at our option. NXG shall not be liable for incidental or consequential damages of any kind or character because of product defects. Some states do not allow limitations on how long an implied warranty lasts and/or do not allow the exclusion or limitation of incidental or consequential damages, so the above limitations and exclusions may not apply.

This Warranty Does Not Cover:

- Damage caused by abuse, accident, misuse, negligence, or improper operation.
- Any product whose serial number has been altered, defaced, or removed.
- Products that have been altered or modified.
- Normal wear and maintenance.
- Damages caused by shipping. (All claims for shipping damage must be made with the carrier.)

Warranty Service

Warranty service must be performed by an authorized service center, usually an NXG speaker systems dealer or its authorized agent. You may obtain a list of authorized service centers by contacting NXG. All warranty repairs must be accompanied by the original bill of sales. No other document is acceptable or is required. This warranty gives you specific legal rights, and you may also have other rights which vary from state to state.

NXG
TECHNOLOGY

16648 North 94th Street
Scottsdale, AZ 85260
1-800-733-0008

NXG reserves the right to revise speaker system specifications without notice.